



HINO 268 SERIES AIR BRAKES 2013

TRUCK CHASSIS SPECIFICATIONS

(NJ8J) SS-NJ072A
GVW: 11,818 kg (26,000 lbs.)

All 2013 models require ultra-low sulfur diesel fuel

DIMENSIONS (On standard specifications)

MODEL	NJ8JTSA	
Wheelbase	A mm(in.)	6,426 (253.0)
Overall length	B mm(in.)	9,921 (390.6)
Overall width	C mm(in.)	2,450 (96.5)
Overall height	D mm(in.)	2,700 (106.3)
Cab to axle	E mm(in.)	4,714 (185.6)
Rear overhang	F mm(in.)	2,464 (97.0)
Frame height at		
Front axle	G mm(in.)	930 (36.6)
Rear axle	H mm(in.)	985 (38.8)
Road clearance (at front axle)	J mm(in.)	285 (11.2)
Tread		
Front	K mm(in.)	2,015 (79.3)
Rear	L mm(in.)	1,835 (72.2)
Turning radius		
Tire	mm(in.)	10,120 (398.4)
Swept	mm(in.)	10,640 (418.9)

CHASSIS WEIGHTS

AT Total weight	kg(lb.)	4,780 (10,540)
Front axle	kg(lb.)	3,010 (6,640)
Rear axle	kg(lb.)	1,770 (3,900)

POWER LINE & PERFORMANCE

[11,818 kg (26,000 lbs.) GVW & 11.00R22.5-14 tires]

Power line	
Max. speed km/h	125
Gradeability (tan.θ) %	34.0
Transmission Model	Allison 2200 RDS
Type	Six-speed automatic
1st.	3.102
2nd.	1.811
3rd.	1.406
Ratios	4th. 1.000
	5th. 0.712
	6th. 0.610
	Rev. 4.492
Rear axle gear ratios	5.570
Tire size	11R22.5-14

ENGINE

Model	HINO J08E-VC
Type:	Diesel, 6 cylinder, in-line, water-cooled
Combustion system:	Direct injection type
Max. output: (SAE Gross)	220HP at 2,500 rpm
Max. torque: (SAE Gross)	706 N•m (520 lb.-ft.) at 1,500 rpm
Bore and stroke:	112 x 130 mm (4.41 x 5.12 in.)
Piston displacement	7.684 L (468.8 cu.in.)
Fuel injection system:	Common rail ND
Governor:	Electronically controlled
Intake system:	Turbocharged and intercooled
Air cleaner:	Paper filter type ("DONALDSON")
Fan clutch:	Bimetal thermostat sensor regulates fan speed
Block heater:	1,000 watts/120V immersion type

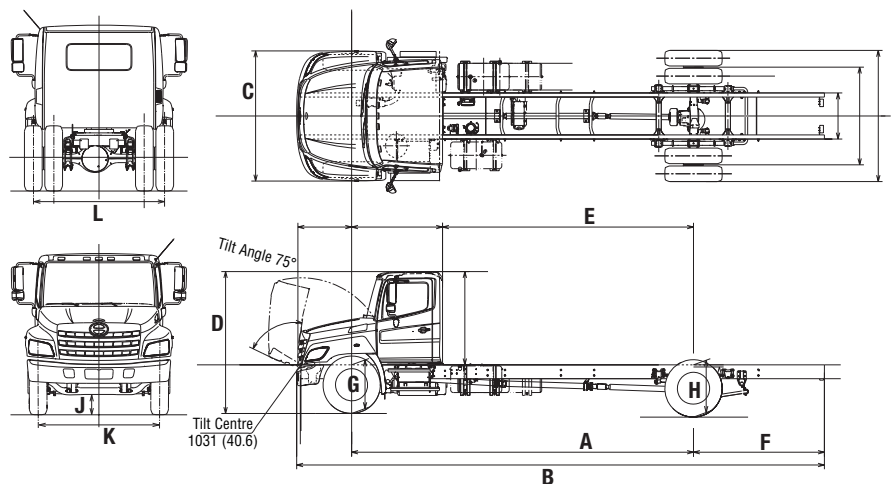

THE QUALITY CHOICE.
www.hinocanada.com

WEIGHT CAPACITIES

Front axle	kg (lbs.) 4,545 (10,000)
Rear axle	kg (lbs.) 8,636 (19,000)
Front spring	kg (lbs.) 5,455 (12,000)
Rear spring	kg (lbs.) 8,636 (19,000)

LIQUID CAPACITIES

Fuel tank ltr.(gal./US)	196.8 (52), aluminum
Cooling system	23.5 (6.21)
ltr.(gal./US)	: ALLISON 2200RDS
Diesel Exhaust Fluid, ltr. (gal.US)	19 (5.02)

AXLE / SUSPENSION

Front axle	MFS-10 series reversed Elliot, "I" beam, Oil lubricated front wheel bearings
Front spring	Taper-leaf springs w/ shock absorbers
Rear axle	RS19-145 series Full-floating, single reduction Single-speed hypoid gears, oil lubricated type
Rear spring	Semi-elliptic main leaf
Option:	2 air bag suspension with shock absorbers and dump valve

FRAME

Ladder type	Straight] section
Width mm(in.)	863.6 (34)
Tensile strength kg/mm ² (lb/in) ²	63.4 (90,143)
Resisting bending moment (one side)	1,188,862 (1,031,900) no reinforcement
kg•mm (in•lbs.)	

STEERING

Type	Tilt and telescopic steering column with lock Recirculating ball, with hydraulic booster integral type
------	---

WHEELS / TIRES

6 Wheels	22.5X8.25, 10-stud disc.
6 Tires	11R22.5(G)
Brand & Pattern	Bridgestone Fr: RIB, Rr: LUG

BRAKES

Service brake	Full air, dual circuit, "S" cam type, leading & trailing shoes, with automatic adjustment
Drum diameter	Front;
x lining width	381 x 101.6 x 18.5
x thickness	(15 x 4 x 0.73)
mm(in.)	Rear;
	419.1 x 177.8 x 21.6 (16.5 x 7 x 0.85)
ABS	Equipped
Parking brake	Spring brake acting on rear wheels
Air dryer for air tank	Equipped with heater
Exhaust brake	Electric-pneumatic with valve in exhaust pipe

CAB EQUIPMENT

Cab construction	- All steel, welded
Seating	- Three
Driver's seat	- Adjustable reclining, covered with fabric, with air suspension and armrest
Passenger's seat	- Bench type, covered with fabric
Seat belts	- 3-point type (driver and passenger), one 2-point type (centre)
Heater/Defroster	- 18,357 BTU/h (4,627 Kcal/h)
Power mirrors, outside rearview	- chrome, 1 flat, heated and 1 convex on each side
Sun visors	- 2
Over-head console	- 2
Air conditioning	
Windshield	- Laminated
Windshield wipers	- Dual electric, 2-speed and intermittent
Cup holders	
Electric power windows	
Electronic cruise control	
Cigarette lighter / 12V power outlet	
Power door locks, keyless entry	

DASH INSTRUMENTATION

Driver information display	
Meters and gauges, metric system	
Speedometer	- km/h (mph)
Odometer	(km/h)
Fuel gauge	
Diesel exhaust fluid gauge	
Coolant temperature gauge	
Engine tachometer	
Warning and pilot lamps and buzzers	
Oil pressure warning lamp and buzzer	
Brake pressure warning lamp and buzzer	
Coolant level warning lamp and buzzer	
Battery charging warning lamp	
High beam indicator lamp	
Turn signal pilot lamp	
Parking brake warning lamp	
Engine control system warning lamp	
ABS warning lamp	
DEF level indicator	

ELECTRICAL EQUIPMENT

Batteries	2, parallel connection, each 12 V
Capacity	1400 CCA
Alternator	12 V, 135 A brushless
Starter	12 V, 4.8 kW
Audio system	AM/FM radio with CD, DVD, GPS & Bluetooth®
Headlamps	2, composite type
Identification lamps (front)	
Stop/Tail lamps	
Back-up lamps	
Turn signals and hazard warning lamps	
Dome lamps	
Front side marker lamps	
Clearance lamps (front) LED type	
Electrical horn (dual)	

CHASSIS EQUIPMENT

Fuel pre-filter	- Pre-filter (dust) and sedimenter (water) with heater - DAVCO
Reflectors	- 2 rear, 2 front side
Hook	- One at front
Chrome bumper	
Chrome grille	

See your authorized Hino Dealer for a complete list of options and accessories.

NOTE : All specifications of the products are with normal manufacturing allowances and tolerances.
HINO MOTORS CANADA, LTD. reserves the right to alter specifications at any time without previous notice.