



# HINO 258LP SERIES AIR BRAKES 2013

## TRUCK CHASSIS SPECIFICATIONS

(NJ8J Lo-Pro) SS-NJ074A  
GVW: 11,570 kg (25,500 lbs.)

All 2013 models require ultra-low sulfur diesel fuel

### DIMENSIONS (On standard specifications)

| MODEL           |           | NJ8JPSA       |                | NJ8JTSA |  |
|-----------------|-----------|---------------|----------------|---------|--|
| Wheelbase       | A mm(in.) | 5,512 (217.0) | 6,426 (253.0)  |         |  |
| Overall length  | B mm(in.) | 9,007 (354.6) | 9,921 (390.6)  |         |  |
| Overall width   | C mm(in.) | 2,430 (95.7)  | 2,430 (95.7)   |         |  |
| Overall height  | D mm(in.) | 2,605 (102.6) | 2,605 (102.6)  |         |  |
| Cab to axle     | E mm(in.) | 3,800 (149.6) | 4,714 (185.6)  |         |  |
| Rear overhang   | F mm(in.) | 2,464 (97.0)  | 2,464 (97.0)   |         |  |
| Frame height at |           |               |                |         |  |
| Front axle      | G mm(in.) | 825 (32.5)    | 825 (32.5)     |         |  |
| Rear axle       | H mm(in.) | 910 (35.8)    | 910 (35.8)     |         |  |
| Road clearance  |           |               |                |         |  |
| (at front axle) | J mm(in.) | 180 (7.1)     | 180 (7.1)      |         |  |
| Tread           |           |               |                |         |  |
| Front           | K mm(in.) | 1,990 (78.3)  | 1,990 (78.3)   |         |  |
| Rear            | L mm(in.) | 1,840 (72.4)  | 1,840 (72.4)   |         |  |
| Turning radius  |           |               |                |         |  |
| Tire            | mm(in.)   | 8,870 (349.7) | 10,210 (402.0) |         |  |
| Swept           | mm(in.)   | 9,390 (369.7) | 10,730 (422.4) |         |  |

### CHASSIS WEIGHTS

| AT Total weight | kg(lb.) | 4,585 (10,110) | 4,625 (10,200) |
|-----------------|---------|----------------|----------------|
| Front axle      | kg(lb.) | 2,870 (6,330)  | 2,935 (6,475)  |
| Rear axle       | kg(lb.) | 1,715 (3,780)  | 1,690 (3,725)  |

### POWER LINE & PERFORMANCE

[11,570 kg (25,500 lbs.) GVW & 245/70R19.5 tires]

| Power line             |                     |
|------------------------|---------------------|
| Max. speed km/h        | 135                 |
| Gradeability (tan.θ) % | 31.6                |
| Transmission Model     | Allison 2200 RDS    |
| Type                   | Six-speed automatic |
| 1st.                   | 3.102               |
| 2nd.                   | 1.811               |
| 3rd.                   | 1.406               |
| Ratios                 | 4th. 1.000          |
|                        | 5th. 0.712          |
|                        | 6th. 0.610          |
|                        | Rev. 4.492          |
| Rear axle gear ratios  | 4.110               |
| Tire size              | 245/70R19.5         |

### ENGINE

| Model                    | HINO J08E-VC                                  |
|--------------------------|---|
| Type:                    | Diesel, 6 cylinder, in-line, water-cooled     |
| Combustion system:       | Direct injection type                         |
| Max. output: (SAE Gross) | 220HP at 2,500 rpm                            |
| Max. torque: (SAE Gross) | 706 N•m (520 lb.-ft.) at 1,500 rpm            |
| Bore and stroke:         | 112 x 130 mm (4.41 x 5.12 in.)                |
| Piston displacement      | 7.684 L (468.8 cu.in.)                        |
| Fuel injection system:   | Common rail ND                                |
| Governor:                | Electronically controlled                     |
| Intake system:           | Turbocharged and intercooled                  |
| Air cleaner:             | Paper filter type ("DONALDSON")               |
| Pre-heater:              | Glow plug type                                |
| Fan clutch:              | Bimetal thermostat sensor regulates fan speed |
| Block heater:            | 1,000 watts/120V immersion type               |

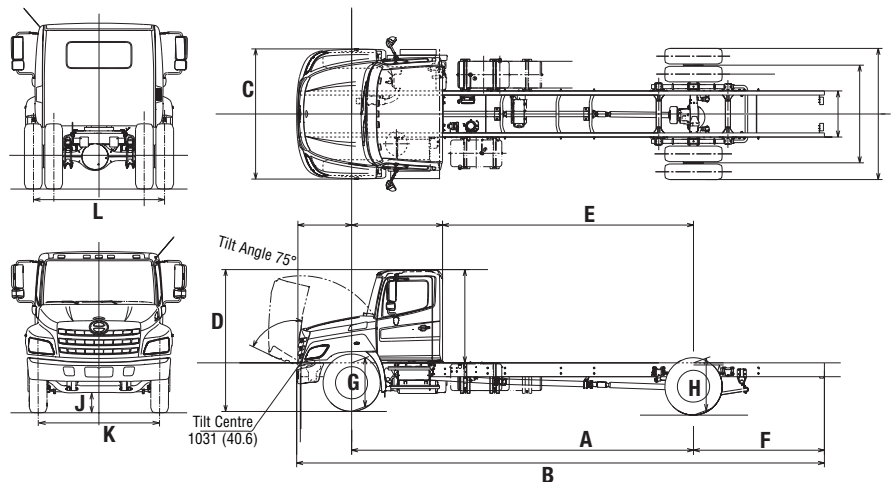

THE QUALITY CHOICE.

www.hinocanada.com

### WEIGHT CAPACITIES

|              |                          |
|--------------|--------------------------|
| Front axle   | kg (lbs.) 5,440 (12,000) |
| Rear axle    | kg (lbs.) 7,955 (17,500) |
| Front spring | kg (lbs.) 3,636 (8,000)  |
| Rear spring  | kg (lbs.) 8,636 (19,000) |

### LIQUID CAPACITIES

|                                     |                      |
|-------------------------------------|----------------------|
| Fuel tank ltr.(gal./US)             | 196.8 (52), aluminum |
| Cooling system                      | 23.5 (6.21)          |
| ltr.(gal./US)                       | : ALLISON 2200 RDS   |
| Diesel Exhaust Fluid, ltr. (gal.US) | 19 (5.02)            |

### AXLE / SUSPENSION

|              |   |
|--------------|---|
| Front axle   | MFS-10 series reversed Elliot, "I" beam, Oil lubricated front wheel bearings                            |
| Front spring | Taper-leaf springs w/ shock absorbers   |
| Rear axle    | RS17-145 series<br>Full-floating, single reduction<br>Single-speed hypoid gears,<br>oil-lubricated type |
| Rear spring  | Semi-elliptic main leaf   |
| Option:      | 2 air bag suspension with shock absorbers and dump valve  |

### FRAME

|   |   |
|---|---|
| Ladder type   | Straight ] section                        |
| Width mm(in.)   | 863.6 (34)                                |
| Tensile strength<br>kg/mm <sup>2</sup> (lb/in) <sup>2</sup> | 63.4 (90,143)                             |
| Resisting bending<br>moment (one side)                      | 1,188,862 (1,031,900)<br>no reinforcement |
| kg•mm (in•lbs.)   |   |

### STEERING

|      |   |
|------|---|
| Type | Tilt and telescopic steering column with lock<br>Recirculating ball, with hydraulic booster integral type |
|------|---|

### WHEELS / TIRES

|                 |                              |
|-----------------|------------------------------|
| 6 Wheels        | 19.5X7.5 10-stud disc.       |
| 6 Tires         | 245/70R19.5(G)               |
| Brand & Pattern | Bridgestone Fr: RIB, Rr: LUG |

### BRAKES

|                        |   |
|------------------------|---|
| Service brake          | Full air, dual circuit, "S" cam type, leading & trailing shoes, with automatic adjustment |
| Drum diameter          | Front;  |
| x lining width         | 381 x 101.6 x 18.5  |
| x thickness            | (15 x 4 x 0.73)   |
| mm(in.)                | Rear;   |
|                        | 381 x 219.0 x 18.5<br>(15 x 8.625 x 0.73)   |
| ABS                    | Equipped  |
| Parking brake          | Spring brake acting on rear wheels  |
| Air dryer for air tank | Equipped with heater  |
| Exhaust brake          | Electric-pneumatic with valve in exhaust pipe   |

### CAB EQUIPMENT

|                                      |   |
|--------------------------------------|---|
| Cab construction                     | - All steel, welded   |
| Seating                              | - Three<br>Driver's seat - Adjustable reclining, covered with fabric, with air suspension and armrest<br>Passenger's seat - Bench type, covered with fabric |
| Seat belts                           | - 3-point type (driver and passenger), one 2-point type (centre)  |
| Heater/Defroster                     | - 18,357 BTU/h (4,627 Kcal/h)   |
| Power mirrors                        | outside rearview, chrome, 1 flat, heated and 1 convex on each side  |
| Sun visors                           | - 2   |
| Over-head console                    | - 2   |
| Air conditioning                     |   |
| Windshield                           | - Laminated   |
| Windshield wipers                    | - Dual electric, 2-speed and intermittent   |
| Cup holders                          |   |
| Electric power windows               |   |
| Electronic cruise control            |   |
| Cigarette lighter / 12V power outlet |   |
| Power door locks                     | keyless entry   |

### DASH INSTRUMENTATION

|  |              |
|--|--------------|
| Driver information display             |              |
| Meters and gauges, metric system       |              |
| Speedometer                            | - km/h (mph) |
| Odometer                               | (km/h)       |
| Fuel gauge                             |              |
| Diesel exhaust fluid gauge             |              |
| Coolant temperature gauge              |              |
| Engine tachometer                      |              |
| Warning and pilot lamps and buzzers    |              |
| Oil pressure warning lamp and buzzer   |              |
| Coolant level warning lamp and buzzer  |              |
| Battery charging warning lamp          |              |
| High beam indicator lamp               |              |
| Turn signal pilot lamp                 |              |
| Brake pressure warning lamp and buzzer |              |
| Parking brake warning lamp             |              |
| Engine control system warning lamp     |              |
| ABS warning lamp                       |              |
| Glow plug pre-heater indicator lamp    |              |
| DEF level indicator                    |              |

### ELECTRICAL EQUIPMENT

|                                       |  |
|---------------------------------------|--|
| Batteries                             | 2, parallel connection, each 12 V          |
| Capacity                              | 1400 CCA                                   |
| Alternator                            | 12 V, 135 A brushless                      |
| Starter                               | 12 V, 4.0 kW                               |
| Audio system                          | AM/FM radio with CD, DVD, GPS & Bluetooth® |
| Headlamps                             | 2, composite type                          |
| Identification lamps (front)          | LED type                                   |
| Stop/Tail lamps                       |  |
| Back-up lamps                         |  |
| Turn signals and hazard warning lamps |  |
| Dome lamps                            |  |
| Front side marker lamps               |  |
| Clearance lamps (front)               | LED type                                   |
| Electrical horn (dual)                |  |

### CHASSIS EQUIPMENT

|                 |   |
|-----------------|---|
| Fuel pre-filter | - Pre-filter (dust) and sedimenter (water) with heater, Davco |
| Reflectors      | - 2 rear, 2 front side  |
| Hook            | - One at front  |
| Chrome grille   |   |
| Chrome bumper   |   |

*See your authorized Hino Dealer for a complete list of options and accessories.*

**NOTE :** All specifications of the products are with normal manufacturing allowances and tolerances.  
HINO MOTORS CANADA, LTD. reserves the right to alter specifications at any time without previous notice.