



# HINO

# HINO 195 SERIES HYBRID 2013

## TRUCK CHASSIS SPECIFICATIONS

**SS-XF306A**  
GVW: 8,850 kg (19,500 lbs.)

All 2013 models require ultra-low sulfur diesel fuel

### DIMENSIONS (On standard specifications)

MODEL		195-2H	195-3H	195-4H
Wheelbase	A mm (in)	3,500 (137.8)	3,800 (149.6)	4,400 (173.2)
Overall length	B mm (in)	5,806 (228.6)	6,106 (240.4)	6,705 (264.0)
Overall width	C mm (in)	2,137 (84.1)	2,137 (84.1)	2,137 (84.1)
Overall height	D mm (in)	2,380 (93.7)	2,380 (93.7)	2,380 (93.7)
Cab width	mm (in)	1,995 (78.5)	1,995 (78.5)	1,995 (78.5)
Frame width	mm (in)	838 (33.0)	838 (33.0)	840 (33.1)
Cab to axle	E mm (in)	2,942 (115.8)	3,242 (127.6)	3,842 (151.2)
Front overhang	mm (in)	1,126.5 (44.4)	1,126.5 (44.4)	1,126.5 (44.4)
Front overhang frame	mm (in)	1,033 (40.7)	1,033 (40.7)	1,033 (40.7)
Rear overhang	F mm (in)	1,175 (46.3)	1,175 (46.3)	1,175 (46.3)
Frame height at Front axle	G mm (in)	744 (29.3)	744 (29.3)	744 (29.3)
	Rear axle H mm (in)	841 (33.1)	841 (33.1)	841 (33.1)
Road clearance (at diff. case)	J mm (in)	206 (8.1)	206 (8.1)	206 (8.1)
Tread	Front K mm (in)	1,655 (65.2)	1,655 (65.2)	1,655 (65.2)
	Rear L mm (in)	1,665 (65.6)	1,665 (65.6)	1,665 (65.6)
Turning radius Tire	mm (in)	6,620 (260.6)	7,120 (280.3)	8,140 (320.5)
Turning radius Swept	mm (in)	7,250 (285.4)	7,760 (305.5)	8,770 (345.3)

### CHASSIS WEIGHTS

AT	Total weight	kg(lb.)	3,358 (7,403)	3,367 (7,423)	3,438 (7,580)
	Front axle	kg(lb.)	2,107 (4,645)	2,132 (4,700)	2,194 (4,837)
	Rear axle	kg(lb.)	1,251 (2,758)	1,235 (2,723)	1,244 (2,743)

### POWER LINE & PERFORMANCE

[ 8,850 kg (19,500 lbs.) GVW & 225/70R19.5 tires]

Power line	
Max. speed km/h	110
Gradeability (tan.θ) %	64.9
Transmission Model	A465
Type	Six-speed automatic
1st.	3.742
2nd.	2.003
3rd.	1.343
Ratios	4th. 1.000
	5th. 0.773
	6th. 0.634
	Rev. 3.539
Rear axle gear ratios	5.571

### ENGINE

Model	HINO J05E-TP (Hybrid)
Type	Diesel, 4-cylinder in-line, water-cooled
Combustion system	Direct injection type
Max. output	210HP at 2,500 rpm
Max. torque	597 N•m (440 lb.-ft.) at 1,500 rpm
Bore and stroke	112 x 130 mm (4.41 x 5.12 in.)
Piston displacement	5.123 L (312.6 CID)
Fuel injection pump	Radial plunger pump (HP-3)
Governor	Electronically controlled
Intake system	Turbo charged and intercooled
Air cleaner	Paper filter type ("DONALDSON")
Fan clutch	Bimetal thermostat sensor regulates fan speed
Exhaust gas after treatment system	DEF - SCR Dosing system
Glow plugs	Standard
Engine block heater	1,000 watts/120V immersion type
Hybrid System	Diesel-Electric Parallel type
Max. motor output	36KW
Max. motor torque	350 Nm @ 1,000 rpm
Battery type	Nickel metal hydride, 288V
Drive mode	idle stop feature

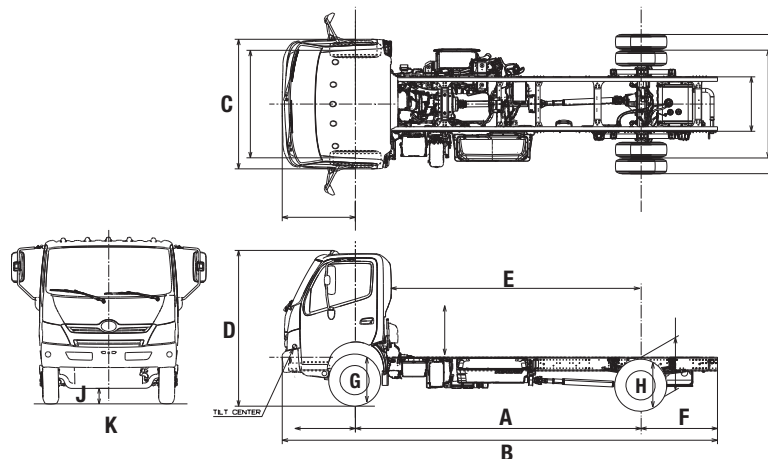

**THE QUALITY CHOICE.**  
www.hinocanada.com

### WEIGHT CAPACITIES

Front axle	kg (lbs.) 3,100 (6,830)
Rear axle	kg (lbs.) 6,200 (13,660)

### LIQUID CAPACITIES

Fuel tank	114 (30)
litr.(gal./US)	
Cooling system	21.0L (5.54 gal./US)
Diesel Exhaust Fluid, ltr. (gal.US)	19 (5.02)

### AXLE / SUSPENSION

Front axle	Reversed Elliot, "I" beam
Front spring	Taper leaf springs with shock absorbers and stabilizer bar
Rear axle	Full-floating, single reduction Single-speed by hypoid gears
Rear spring	Taper-leaf springs with shock absorbers

### FRAME

Ladder type	Straight section
Max. section (depth x flange x thickness)	210 x 70 x 5.0 (8.27 x 2.8 x 0.20) for 137.8",149.6" WB
mm(in.)	212 x 70 x 6.0 (8.35 x 2.8 x 0.24) for 173.2" WB
Yield point of material kg/mm2 (PSI)	40.0 (56,900)
Resisting bending moment kgf•mm (in•lbs.)	8,144,000 (706,900) for 137.8",149.6" WB 9,748,000 (846,100) for 173.2" WB
Front bumper	Resin material

### STEERING

Type	Tilt and telescopic steering column with lock Recirculating ball, with hydraulic booster integral type
------	---

### WHEELS / TIRES

6 Wheels	19.5X6K-127, 6-stud disc.
6 Tires	225/70R19.5
Brand & Pattern	Bridgestone Fr-RIB Rr-LUG type

### BRAKES

Service brakes	Hydraulic system with disc brakes for front and rear wheels with ABS
Disc diameter x pad area (cm <sup>2</sup> ) x thickness mm(in.)	Front; 348.4 x 111 x 13 (13.72 x 4.37 x 0.51) Rear; 348.4 x 111 x 13 (13.72 x 4.37 x 0.51)
Control	Hydraulic assist, dual circuit
Parking brake	Mechanical, internal expanding acting on transmission output shaft
Drum diameter mm(in.)	203 (8)
Exhaust brake	Electric-pneumatic with valve in exhaust pipe

### CAB EQUIPMENT

Cab construction	- All steel, welded
Seating	- Three
Driver's seat	- 2-way adjustable high-back seat, fabric covered, magnetic suspension
Passenger's seat	- Fixed high-back seat, fabric covered
Center passenger's seat	- Foldaway type with seat back console, fabric covered
Seat belts	- 3-point type for driver and passenger, 2-point type for center passenger
Heater/Defroster	- 18,596 BTU/h ( 4,687 Kcal/h )
Air conditioning	
Outside rearview mirrors	- 2, heated, remote control
Sun visors	- 2
Over-head console	- 2
Windshield	- Laminated
Windshield wipers	- Dual electric, 2-speed and intermittent
Cup Holders	2, dash mounted
Electric power windows	
Cigarette lighter	
Electric door locks	keyless entry
Door pockets	
Vinyl floor covering	
Cruise control	

### CHASSIS EQUIPMENT

Fuel pre-filter and sedimenter	with heater
Towing hook	
Reflectors	2
Chrome grille	

### DASH INSTRUMENTATION

Meters and gauges, metric system	
Speedometer	- km/h (mph)
Odometer	- km
Fuel gauge	
Coolant temperature gauge	
Engine tachometer	
Economy meter	
Warning and pilot lamps and buzzers	
Oil pressure warning lamp and buzzer	
Brake fluid level warning lamp	
Battery charging warning lamp	
High beam indicator lamp	
Turn signal pilot lamp	
Parking brake warning lamp	
Engine control system warning lamp	
ABS warning lamp	
Exhaust brake indicator lamp	
Transmission oil temperature warning lamp	
Fuel level warning lamp	
Hazard indicator lamp	
Economy indicator lamp	
Air cleaner warning lamp	
DEF level indicator	

### ELECTRICAL EQUIPMENT

Batteries	2, 12V GR27, parallel connection
Capacity	1,244 CCA
Alternator	12 V, 130 A
Starter	12 V, 3.35 kW
Audio system	AM/FM radio with CD, DVD, GPS & Bluetooth®
Headlamps	2, composite type
Stop/Tail lamps	
Identification lamps	
Back-up lamps	
Back-up warning buzzer	
License plate lamp	
Directional indicator and hazard lamp	
Dome lamp	
Clearance lamps	
Parking lamps	
Day time running lights	
Fender marker lamps	
Electric Horn	

**See your authorized Hino Dealer for a complete list of options and accessories.**

**NOTE : All specifications of the products are with normal manufacturing allowances and tolerances.  
HINO MOTORS CANADA, LTD. reserves the right to alter specifications at any time without previous notice.**